



TRI-STATE® Hex Buffers

General Description

These devices provide six, two-input buffers in each package. Both the standard (7400 compatible) TTL technology, and the "true tenth-power" (74L compatible) low power versions are available for each of the four types. One of the two inputs to each buffer is used as a control line to gate the output into the high-impedance state, while the other input passes the data through the buffer. The 95 and 97 present the true data at the outputs, while the 96 and 98 are inverting. On the 95 and 96 versions, all six control lines for TRI-STATE enable are common in a single line. On the 97 and 98 versions, four buffers are enabled from a common line, and the other two buffers from a separate common line. In all cases, the outputs are placed in the TRI-STATE condition by applying a high logic level to the control pins. With either the standard TTL or the low power versions of

these circuits, it is possible to connect over 100 like devices to a common bus line and still have adequate drive capability.

Features

Type	Typical Power Dissipation	Typical Propagation Delay
95, 97	325 mW	12 ns
L95, L97	20 mW	34 ns
96, 98	295 mW	11 ns
L96, L98	15 mW	31 ns

- Pin equivalent to DM54365 (95), DM54366 (96), DM54367 (97), DM54368 (98)

Connection Diagrams

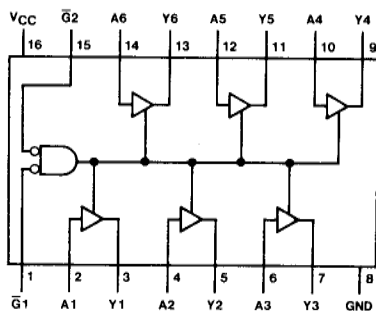

7095 (J,W)
70L95 (J,W)

8095 (N)
80L95 (N)

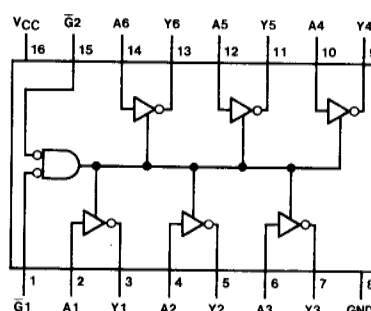

7096 (J,W)
70L96 (J,W)

8096 (N)
80L96 (N)

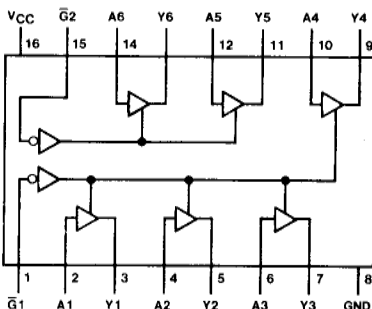

7097 (J,W)
70L97 (J,W)

8097 (N)
80L97 (N)

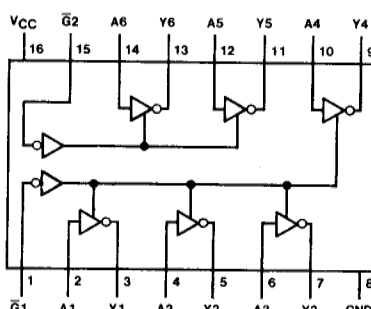

7098 (J,W)
70L98 (J,W)

8098 (N)
80L98 (N)

Truth Table (Each Driver)

95, L95				96, L96				97, L97			98, L98		
Inputs		Outputs		Inputs		Outputs		Inputs		Outputs	Inputs		Outputs
G1	G2	A	Y	G1	G2	A	Y	G	A	Y	G	A	Y
H	X	X	Hi-Z	H	X	X	Hi-Z	H	X	Hi-Z	H	X	Hi-Z
X	H	X	Hi-Z	X	H	X	Hi-Z	L	H	H	L	H	L
L	L	H	H	L	L	H	L	L	L	L	L	L	L
L	L	L	L	L	L	L	H	L	L	L	L	L	H

**Electrical Characteristics** over recommended operating free-air temperature range (unless otherwise noted)

Parameter		Conditions		DM70/80			DM70/80			Units		
				95, 96, 97, 98			L95, L96, L97, L98					
				Min	Typ (1)	Max	Min	Typ (1)	Max			
V _{IH}	High Level Input Voltage			2			2			V		
V _{IL}	Low Level Input Voltage					0.8			0.7	V		
V _I	Input Clamp Voltage	V _{CC} = Min, I _I = -12 mA				-1.5			N/A	V		
I _{OH}	High Level Output Current			DM70		-2.0			-1.0	mA		
				DM80		-5.2			-1.0			
V _{OH}	High Level Output Voltage	V _{CC} = Min, V _{IH} = 2 V V _{IL} = Max, I _{OH} = Max		2.4	3.1		2.4			V		
I _{OL}	Low Level Output Current			DM70		32			2.0	mA		
				DM80		32			3.6			
V _{OL}	Low Level Output Voltage			DM70		0.4			0.3	V		
				DM80		0.4			0.4			
I _{O(OFF)}	Off-State (High-Impedance State) Output Current		V _{CC} = Max V _{IH} = 2 V V _{IL} = Max	V _O = 0.3 V						-10	μA	
				V _O = 0.4 V				-40				
				V _O = 2.4 V				40				10
I _I	Input Current at Maximum Input Voltage	V _{CC} = Max, V _I = 5.5 V				1			1	mA		
I _{IH}	High Level Input Current	V _{CC} = Max, V _I = 2.4 V				40			10	μA		
I _{IL}	Level Input Current	A Input	V _{CC} = Max	Both \bar{G} Inputs at 2 V	V _I = 0.3 V						-10	μA
					V _I = 0.5 V			-40				
					Both \bar{G} Inputs at 0.4 V	V _I = 0.3 V					-0.18	
		V _I = 0.4 V				-1.6						
		\bar{G} Input		V _I = 0.3 V					-0.18			
				V _I = 0.4 V			-1.6					
I _{OS}	Short Circuit Output Current	V _{CC} = Max (2)		-40		-115	-3		-15	mA		
I _{CC}	Supply Current	V _{CC} = Max		95, 97		65	85		4.0	5.8	mA	
				96, 98		59	77		3.0	4.5		

Note 1: All typical values are at V_{CC} = 5 V, T_A = 25°C.

Note 2: Not more than one output should be shorted at a time, and for the DM70/DM8095, 96, 97, 98 duration of short circuit should not exceed one second.

Switching Characteristics V_{CC} = 5 V, T_A = 25°C

Parameter		Conditions			DM70/80				DM70/80				Units
					95, 97		96, 98		L95, L97		L96, L98		
					Typ	Max	Typ	Max	Typ	Max	Typ	Max	
t _{PLH}	Propagation Delay Time, Low-to-High Level Output	C _L = 50 pF	R _L = 400 Ω	R _L = 4 k Ω	10	16	11	17	30	60	26	48	ns
t _{PHL}	Propagation Delay Time, High-to-Low Level Output				14	22	10	16	37	75	35	53	
t _{ZH}	Output Enable Time to High Level				21	35	21	35	47	96	42	90	
t _{ZL}	Output Enable Time to Low Level				24	37	24	37	21	45	42	75	
t _{HZ}	Output Disable Time from High Level	C _L = 5 pF			6	11	6	11	47	90	25	43	ns
t _{LZ}	Output Disable Time from Low Level		16	27	16	27	30	63	34	63			